

Instruction Manual for Micro Hematocrit Centrifuge DSC-100MH-2

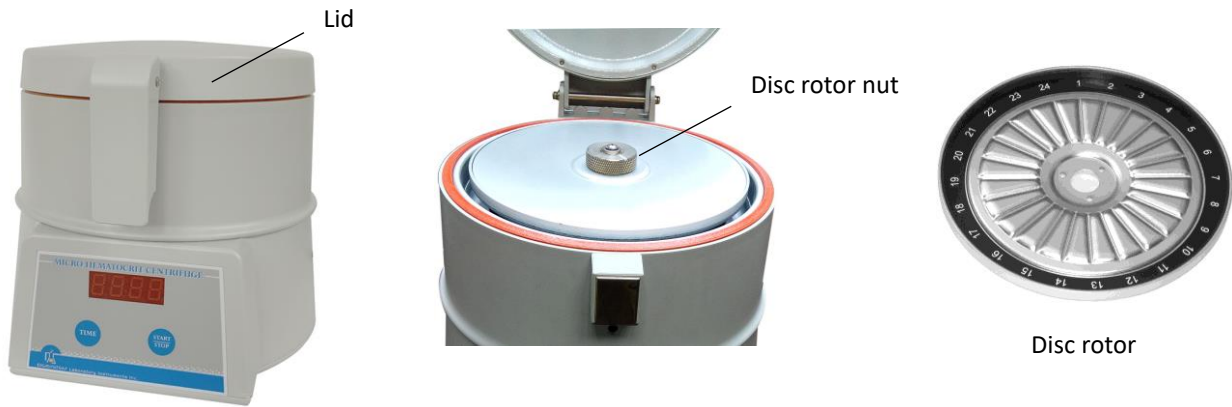

Warnings:

- * Do not open the lid before the centrifuge stops completely.
- * Do not remove the centrifuge during operation.
- * Do not put objects on the top of the lid.
- * Do not disassemble the centrifuge by yourself. In the event of a malfunction, the centrifuge should be repaired by a qualified technician. Before repairing, turn off the power.



Steps:

1. Place the centrifuge on a flat surface. Plug the centrifuge into a properly grounded outlet which corresponds with the electrical requirements on the label back on machine.
2. Open the 'Lid', and then turn the ' Disc cover nut' counter-clockwise to remove 'Disc cover'.
3. Set an even number of capillary tubes in a symmetrical position. Place the sealed end toward the outside, making sure that the tubes are seating in the grooves and firmly against the rubber cushion.

Caution: Before setting capillary tubes, please make sure that the rubber gasket exists and adjoins the edge of the "Disc rotor". Without the rubber cushion, the capillary tubes will break during operation.

4. Turn the ' Disc cover nut' clockwise to screw down the 'Disc cover'. And make sure it is screwed down. Then close the 'Lid'. Please see the figure 1 to know how to close the lid.

Caution: Make sure that the ' Dick cover' is screwed down, otherwise the capillary tube will break during operation.

5. Press  set the time value.
6. Press  to start the centrifuge directly.

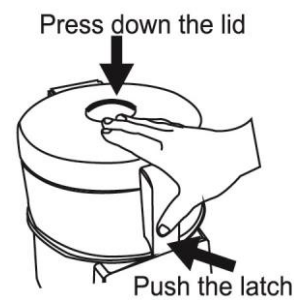



Figure 1

7. When the setting time reaches to the end, the bell signal “Don” will be heard, and the display shows OPEN.
8. After the centrifuge stops completely, please open the lid, and take out the capillary tubes and use the “Micro hematocrit reader” to measure the packed cell volume (PCV).
9. During the operation, you may push the button  to stop the machine.
However, do not use stop action frequently unless it is in an emergent condition.

Maintenance and care:

Keep the centrifuge clean all the time. Cleaning can be done with a damp cloth. Avoid the use of solvents as they may damage the product housing, rotor.

Circuit Diagram:

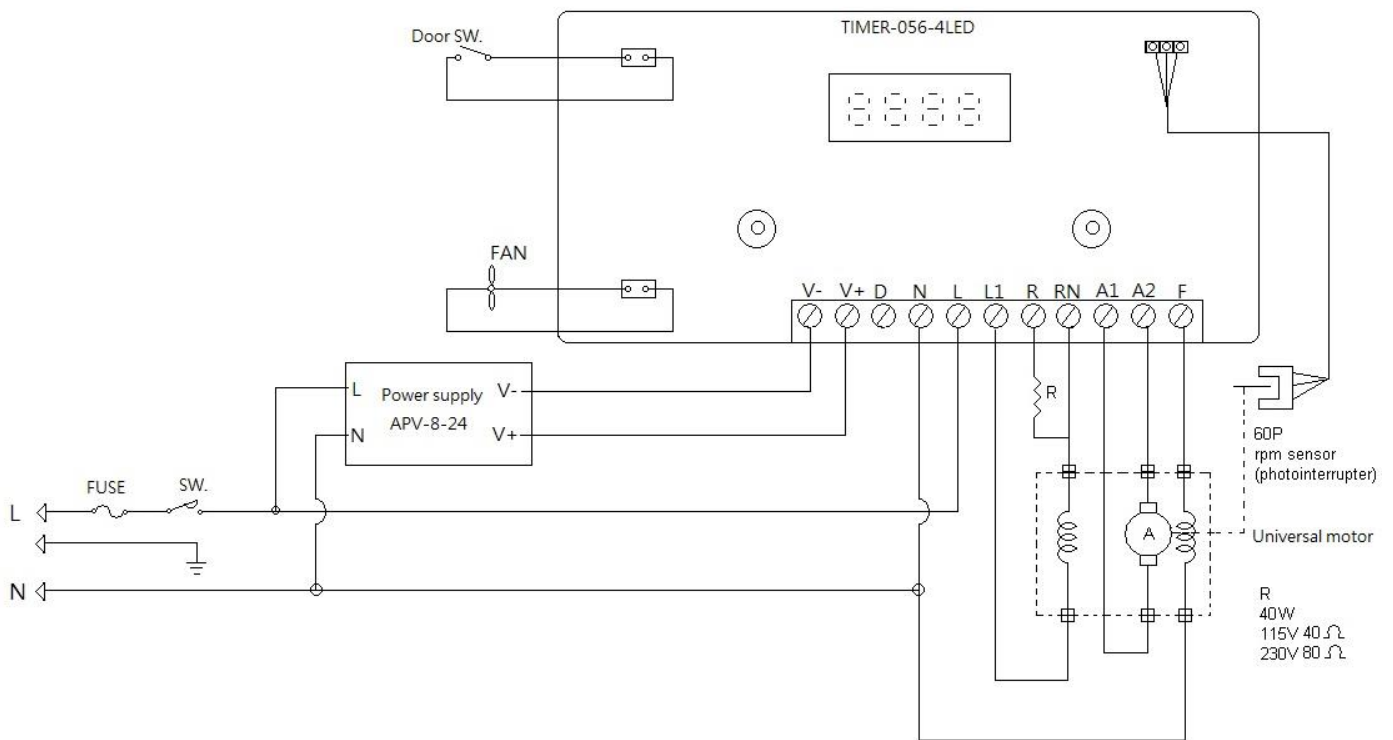

Using your micro hematocrit reader:

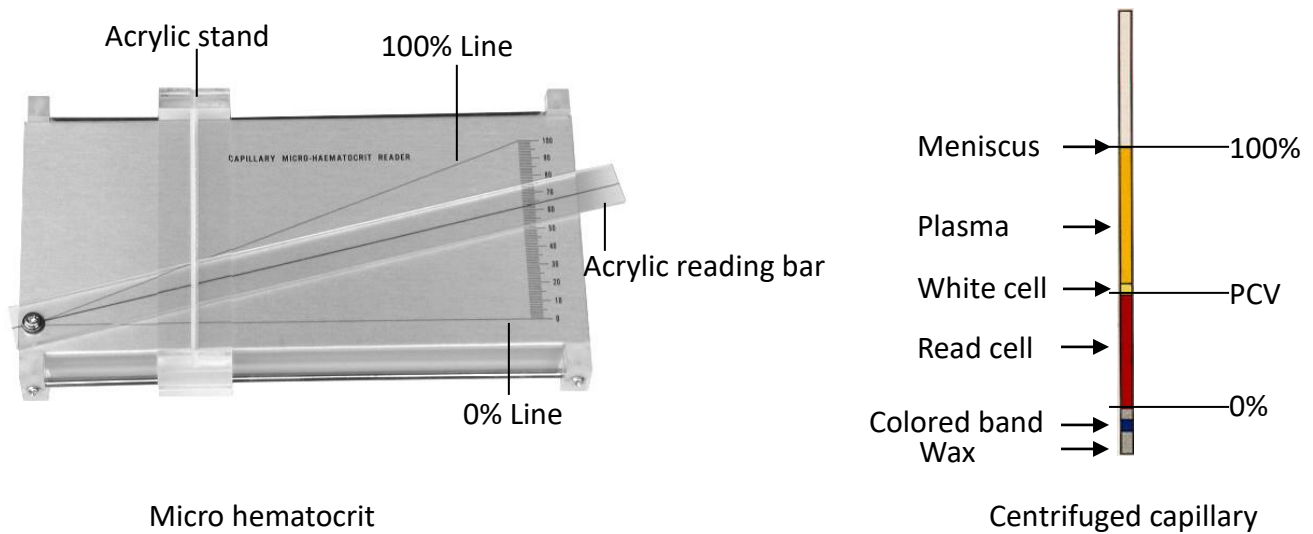

Caution:

- * Read the results immediately after the centrifuge stops.
- * Do not place the tubes upright until they are read. The red cells will slide if the tubes are left in a horizontal position and the packed cell volume (PCV) will be falsely increased.

1. Place the centrifuged capillary tube in the groove of the "Acrylic stand".
2. Let the interface of the wax and the red cell align with the "0% Line".
3. Slide the "Acrylic stand" right or left until the "Meniscus" of the "Plasma" intersects the "100% line".
4. Move the "Acrylic reading bar" until the top of the red cell column intersects the line on the "Acrylic reading bar".
5. The reading that corresponds to the top of the red cell column is the packed cell value (PCV).

Service Manual

Troubleshooting Guide

Caution: Always disconnect the power cord before troubleshooting.

Trouble	Cause	Remedy
Motor is not working	Power cord is not securely connected.	Reconnect it securely.
	Fuse is burnt.	Replace a fuse.
	Lid is not closed well.	Open lid and close it again.
	The setting of micro switch is not proper or it is broken.	Contact the distributor for repair.
	The contact of carbon and rotor is not well.	Contact the distributor for repair.
	The wiring of motor is not well.	Contact the distributor for repair.
The power is not cut off when open the lid	The setting of micro switch is not proper.	Contact the distributor for repair.
Capillary tubes break during operation	Rubber gasket doesn't set well.	Set it again.
	Rubber gasket is worn-out.	Replace a new one.
	Disc cover doesn't be screwed down.	Screw it again and make sure to screw it down.